



821 BROCK RD. UNIT 1  
 PICKERING, ONT  
 L1W 3L6  
 TEL:(905)837-1115  
 FAX:(905)837-7588

SOLD TO:

WALL PATTERN: \_\_\_\_\_

TAG NAME: \_\_\_\_\_

FLOOR PATTERN: \_\_\_\_\_

DATE: \_\_\_\_\_

MIL: \_\_\_\_\_

P.O: \_\_\_\_\_

MUST PROVIDE PERIMETER

SAFETY LEDGE  
 IF LEDGE VARIES PLEASE INDICATE

CHECK OFF BEAD TYPE

TOTAL: \_\_\_\_\_

[ ] NO [ ] YES  
 RIGHT LEDGE \_\_\_\_\_ IN. LEFT LEDGE \_\_\_\_\_ IN.  
 END LEDGE \_\_\_\_\_ IN.

[ ] STANDARD  
 [ ] OTHER \_\_\_\_\_  
 [ ] NO BEAD \_\_\_\_\_ IN. OVERLAP

RIGHT HAND  
 STANDING IN SHALLOW END

MONARCH

MEASUREMENTS

A
B
C
D
D2
E
F
G
H
I
J
K
1
2
3
4
5
6
7
8
9
10

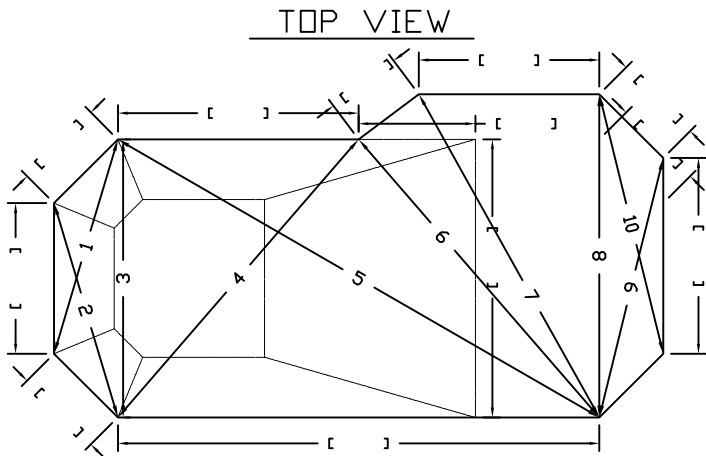
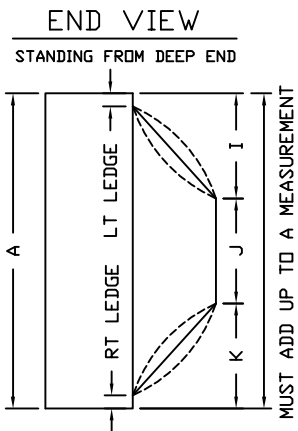

FOX CORNERS

YES  
 NO

JUST AN EXAMPLE:  
 IF STEP IS RADIUS  
 PLEASE INDICATE

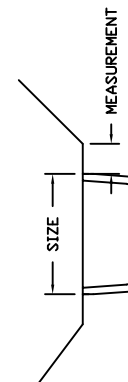

SIDE VIEW

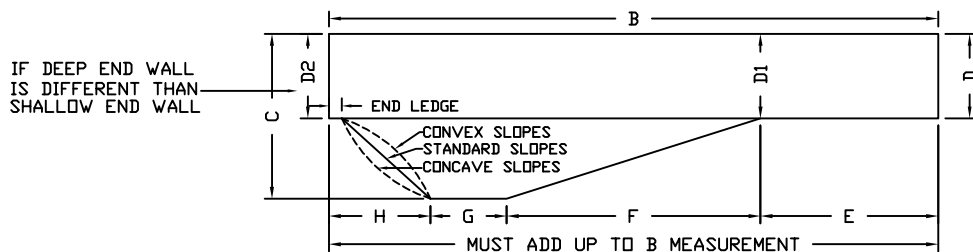

ATTENTION

INDICATE WHERE THE STEP IS LOCATED.  
 PROVIDE THE SIZE OF STEP AND A  
 MEASUREMENT FROM THE CLOSEST PANEL  
 JOINT, AS SHOWN IN THE EXAMPLE.

SIZE OF STEP

DISTANCE

SLOPES

STANDARD  
 CONVEX  
 CONCAVE

COVE PROFILE

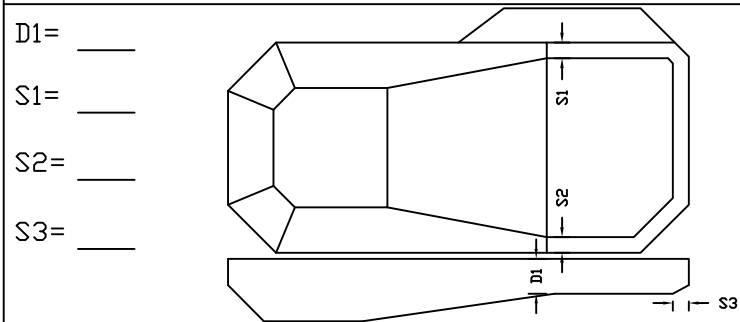

DEEPER BREAK PROFILE

