



821 BROCK RD. UNIT 1
 PICKERING, ONT
 L1W 3L6
 TEL:(905)837-1115
 FAX:(905)837-7588

SOLD TO:

WALL PATTERN: _____

TAG NAME: _____

FLOOR PATTERN: _____

DATE: _____

MIL: _____

P.D: _____

LEFT HAND
 STANDING FROM S.E

MUST PROVIDE PERIMETER

SAFETY LEDGE
 IF LEDGE VARIES PLEASE INDICATE
 NO YES
 RIGHT LEDGE _____ IN. LEFT LEDGE _____ IN.
 END LEDGE _____ IN.

CHECK OFF BEAD TYPE

- STANDARD
- OTHER _____
- NO BEAD _____ IN. OVERLAP

TOTAL: _____

CONT. FULL-L

SLOPES

- STANDARD
- CONVEX
- CONCAVE

MEASUREMENTS

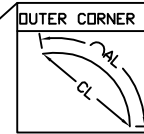
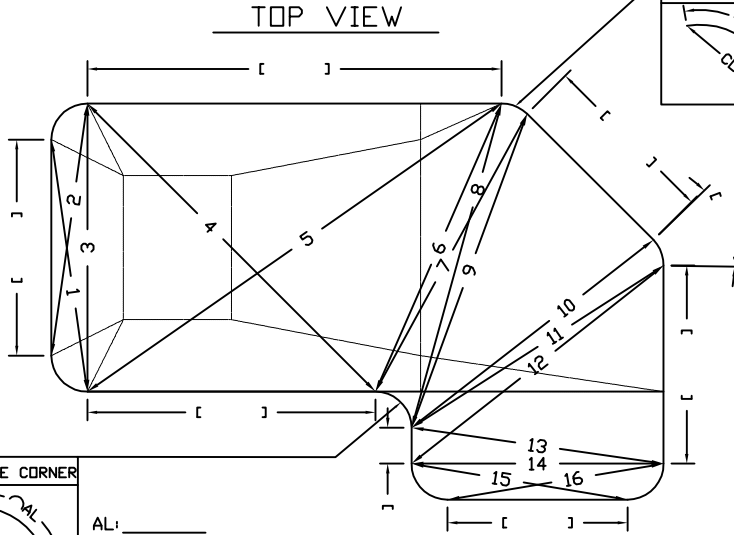
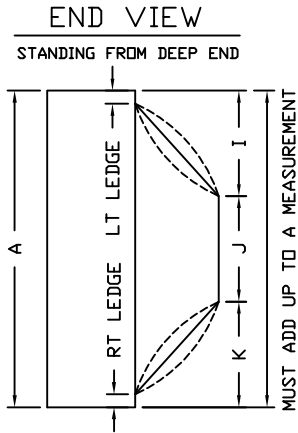

AL: _____
 CL: _____

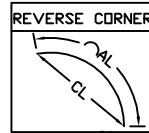

AL: _____
 CL: _____

INDICATE CORNER TYPE

2' CORNER

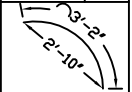

4' CORNER

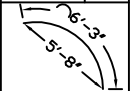

OTHER



AL: _____
 CL: _____

IF DEEP END WALL IS DIFFERENT THAN SHALLOW END WALL

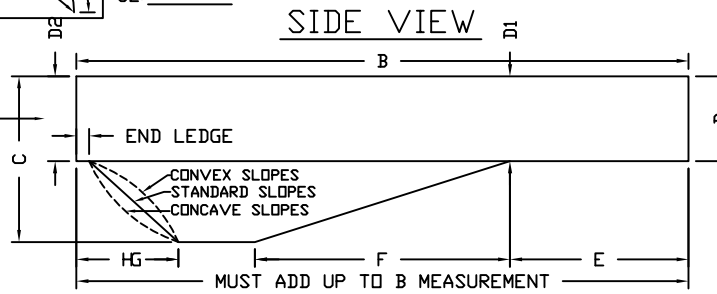

ATTENTION

INDICATE WHERE THE STEP IS LOCATED. PROVIDE THE SIZE OF STEP AND A MEASUREMENT FROM THE CLOSEST PANEL JOINT, AS SHOWN IN THE EXAMPLE.

SIZE OF STEP

DISTANCE

A
B
C
D
D2
E
F
G
H
I
J
K
1
2
3
4
5
6
7
8
9
10
11
12
13
14
15
16

COVE PROFILE

D1= _____
 S1= _____
 S2= _____
 S3= _____

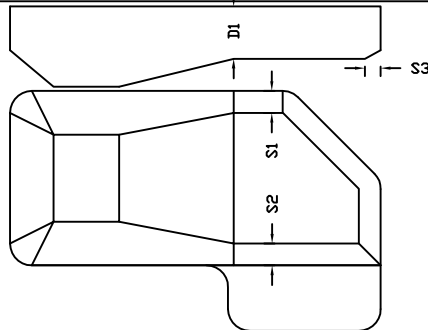

DEEPER BREAK PROFILE

D1= _____
 S1= _____
 S2= _____

